

HELI

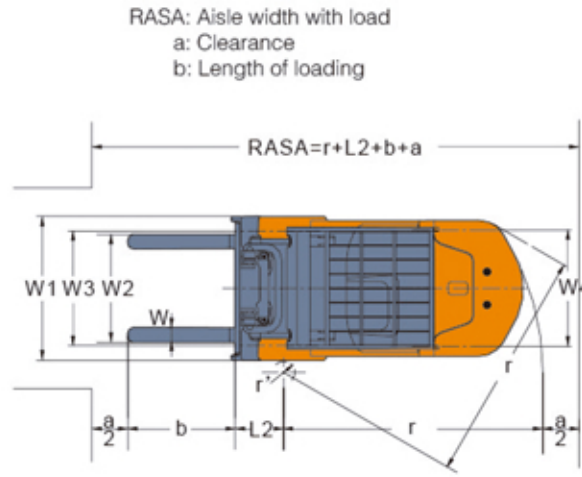
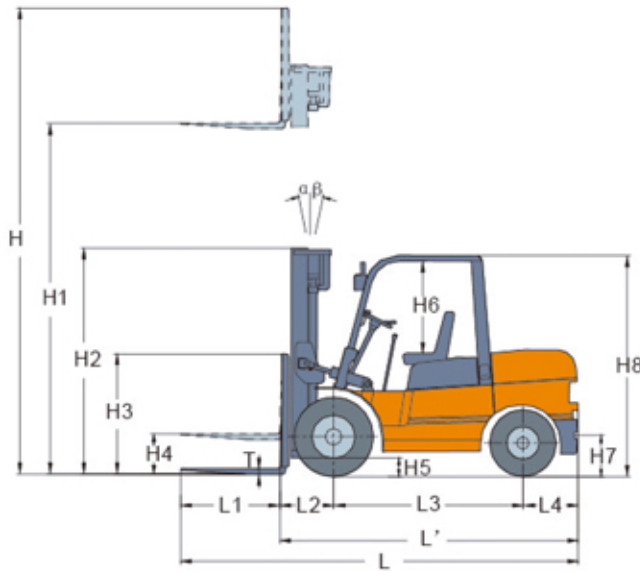

Clearance from the ground	
Drive axle	190
Steering axle	240
Balance weight	220
Frame	230

Standard configuration

Standard Fork	Overhead Guard	Two-spool Control Valve	Tool Kits
Standard Fork Carriage	Single Air Filter	Pneumatic Tyres	
M300 2-stage Mast	Standard Muffler	Standard Seat	

Optional

Cab	Fences	Rear Working Lights	Tilt Cylinder Sleeve
Beacon	Dual Tyres	Non-standard Fork Carriage	Steering Cylinder Sleeve
Dual Air Filter	Solid Tire	Three/Four/Five-spool Control Valve	Full Free 2-stage Mast
Heater	Longer Fork	Vertical Exhaust	Full Free 3-stage Mast
Electric Fan	Suspension seat	Spark Arrester Muffler	
Fire Extinguisher	Windshield glass	Purifying Muffler	

Attachment selection

Sideshifter	Carton Clamp	Tyre Clamp	Single Double Pallet Handlers
Fork Positioner	Rotator	Drum Clamp	Double Wide Sideshifters
Paper Roll Clamp	Bale Clamp	Fork Clamp	Load Stabilizer
Push/Pull	Block Clamp	Turnloads	Tipping Multi-Purpose Clamp

HELI



H series 4-5t

Internal Combustion counterbalanced Forklift Truck



H series 4-5t

Internal Combustion counterbalanced Forklift Truck



www.umina.pe

/

www.montacargasheli.pe



📍 Pasaje Miguel Grau Mz. D Lt.9 San Gabriel - Villa María del Triunfo Lima - Perú

☎ 981449430 - 977392534 - 915121637

✉ ventas@umina.pe

HELI
LIFTING THE FUTURE

H series / HIGH EFFICIENT
ENERGY EFFICIENT



H series 4-5t

Internal Combustion counterbalanced Forklift Truck

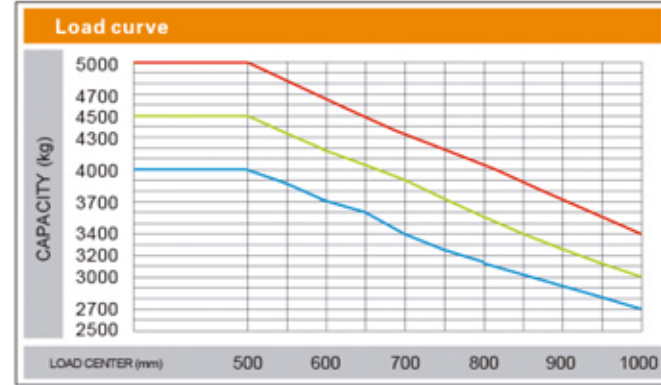

Note: The vertical axis stands for load capacity and the horizontal axis stands for load center which is calculated from the front of the fork. The base point of the standard load refers to the center position of the cube with 1000mm length of side. When mast is tilted forward, nonstandard fork usage or load with over wide goods, load capacity will be reduced. Different load capacity in different load center can be known in time through load chart.

Engine Model and Main Specification for Option					
Configuration No.		CPC(D)40/45/50-WX5	CPC(D)40/45/50-WX8	CPD40/45/50-M2/M3	CPY(Q)D40/45/50-TY5/TY6
Battery(voltage/capacity)	v/Ah	24/80			12/100
Brand/Model		Xichai CA4110	Xichai 4DX23-82GG3U	Mitsubishi S6S	GM4.3Certificate (Non-Certificate) Dual Fuel Engine
Rated power/rotating speed	KW/rpm	60/2200	60/2200	52/2300	Gas: 70/2300, LPG: 76.6/2300
Rated torque/rotating speed	Nm/rpm	505/1400-1600	320/1600-1800	248/1700	Gas: 287/1700, LPG: 323.5/1700
Cylinder number(bore x stroke)		4-110 x 125	4-102-118	6-94X120	6-101.5X88.39
Displacement	L	4.752	3.85	4.996	4.29/4.18
Engine fuel tank capacity	L	90			
Number of gears(fwd/bwd)		2-2 Manual Shift*		2-1 Power Shift	

Note:*Suitable for mechanical drive.

Mast Lift Height/Fork Length													
Wide View Mast Lift Height(mm)	2600	2700	3000*	3300	3500	3700	3750	4000	4250	4500	5000	5500	6000
Full Free 2-stage Mast Lift Height(mm)	2610	2710	3000	3300	3500	3750	4000	4500	5000	5500			
Full Free 3-stage Mast Lift Height(mm)	3920	4350	4500	4700	4800	5000	5400	6000					
Fork Length(mm)	1070*	1220	1370	1520	1670	1820	1970	2120					

Note: *Shown standard configuration,5T forklift standard length is 1220mm of fork.



Manufacturer and technical parameters

Data and design Characteristics								
Character								
1.01	Manufacturer	HELI						
1.02	Model	CPC(Q)D/CPY(QY)D40	CPC(Q)D/CPY(QY)D45	CPC(Q)D/CPY(QY)D50	CPC40	CPC45	CPC50	
1.03	Power type	Diesel/Gasoline/Liquefied gas-Dual fuel						
1.04	Rated capacity	Kg	4000	4500	5000	4000	4500	5000
1.05	Load center	mm	500					
1.06	Driving mode	Sit-type						
Dimensions								
2.01	Overall max.lifting height(with backrest)	mm(H)	4250					
2.02	Std.lifting height	mm(H1)	3000					
2.03	Height mast retracted(upright)	mm(H2)	2275					
2.04	Backrest height(from upper face of forks)	mm(H3)	1250					
2.05	Free lift height	mm(H4)	150					
2.06	Min.ground clearance under mast	mm(H5)	175					
2.07	Overhead guard clearance (from face of seat)	mm(H6)	1020					
2.08	Coupler height	mm(H7)	380					
2.09	Overall height(overhead guard)	mm(H8)	*2350/2270/2230					
2.10	Overall length(with fork/without fork)	mm(L/L')	4140/3080	4170/3100	4364/3144	4140/3080	4170/3100	4364/3144
2.11	Front overhang	mm(L2)	560					
2.12	Wheel base	mm(L3)	2000					
2.13	Rear overhang	mm(L4)	520	540	584	520	540	584
2.14	Overall width	mm(W1)	1480					
2.15	Lateral fork adjustment (outside of fork)(Max./Min.)	mm(W2)	1330/300					
2.16	Tread(Front/Rear)	mm(W3/W4)	1180/1190					
2.17	Min.Turning radius(inside)	mm(r')	220					
2.18	Min.Turning radius(outside)	mm(r)	2720	2740	2800	2720	2740	2800
2.19	Min.right angle stacking aisle width	mm(Ast)	2480	2500	2550	2480	2500	2550
2.20	Mast tilting angle(Front/Rear)	mm(α/β)	6°/12°					
2.21	Fork size	mm(L1xWxT)	1070x150x50	1220x150x50	1070x150x50	1220x150x50	1220x150x50	
Performance								
3.01	Max.Travelling speed(loaded/unloaded)	km/h	24/25			18/19		
3.02	Lifting speed(loaded/unloaded)	mm/s	460/520			450/490		
3.03	Lowering speed(loaded/unloaded)	mm/s	300 < < 600					
3.04	Max.Draw bar(loaded/unloaded)	KN	30/18					
3.05	Max.Gradeability(loaded/unloaded)	%	20/20					
Wheel and tyre								
4.01	Wheel number X=drive wheel(front/rear)	Front two rear two (Double tyre front four rear two)						
4.02	Tyre type(front/rear)	Pneumatic tyre						
4.03	Tyre size(front/rear)	8.25-15-14PR 7.00-12-12RR	300-15-18PR 7.00-12-12RR	8.25-15-14PR 7.00-12-12RR	300-15-18PR 7.00-12-12RR			
4.04	Double tyre size(front/rear)	8.25-15-14PR/7.00-12-12RR						
4.05	Service brake	Hydraulic-foot pedal			Vacuum booster			
4.06	Parking brake	Mechanical-hand brake lever						
Weight								
5.01	Weight	Kg	6310	6510	6760	6100	6380	6700

Notes:* 2350mm is for standard mast height.
2270mm is for truck travelling in the container.
2230mm is for truck operating in the container.



WIDE VIEW MAST									
Mast model	Max. lifting height	Load capacity (load center 500mm)(kg)			Mast height, lowered(mm)	Mast tilting angle (α/β)	Service weight (kg)		
		CPCD40	CPCD45	CPCD50			CPCD40	CPCD45	CPCD50
M260	2600	4000	4500	5000	2075	6° / 12°	6510	6710	6970
M270	2700	4000	4500	5000	2125	6° / 12°	6520	6720	6980
*M300	3000	4000	4500	5000	2275	6° / 12°	6540	6740	7000
M330	3300	4000	4500	5000	2425	6° / 12°	6560	6760	7020
M350	3500	4000	4500	5000	2525	6° / 12°	6580	6780	7040
M370	3700	4000	4500	5000	2625	6° / 12°	6590	6790	7050
M375	3750	4000	4500	5000	2650	6° / 12°	6600	6800	7060
M400	4000	4000	4500	5000	2825	6° / 6°	6610	6810	7070
M425	4250	3800 *4000	4300 *4500	4700 *5000	2950	6° / 6°	6670	6870	7130
M450	4500	3700 *4000	4200 *4500	4500 *5000	3075	6° / 6°	6680	6880	7140
M475	4750	3500 *3700	4000 *4200	4250 *4600	3200	6° / 6°	6700	6900	7160
M500	5000	3200 *3400	3600 *4000	4000 *4200	3325	6° / 6°	6720	6920	7180
M550	5500	2900 *3200	3200 *3600	3600 *3800	3575	3° / 6°	6730	6930	7190
M600	6000	2600 *2900	3000 *3200	3300 *3600	3825	3° / 6°	6750	6950	7210

Note: (1)*stands for the rated capacity when the front tyre is double-tyre.(2) *stands for standard configuration.

WIDE VIEW FULL FREE 2-STAGE MAST										
Mast model	Max. lifting height	Load capacity (load center 500mm)(kg)			Mast height, lowered(mm)	Free lift (with backrest)(mm)	Mast tilting angle (α/β)	Service weight (kg)		
		CPCD40	CPCD45	CPCD50				CPCD40	CPCD45	CPCD50
ZM261	2610	4000	4500	5000	2110	530	6° / 12°	6615	6815	7075
ZM271	2710	4000	4500	5000	2160	580	6° / 12°	6640	6840	7100
ZM300	3000	4000	4500	5000	2305	725	6° / 12°	6690	6890	7150
ZM330	3300	4000	4500	5000	2455	875	6° / 12°	6705	6905	7165
ZM350	3500	4000	4500	5000	2555	975	6° / 12°	6715	6915	7175
ZM375	3750	4000	4500	5000	2680	1100	6° / 12°	6730	6930	7190
ZM400	4000	4000	4500	5000	2805	1225	6° / 6°	6745	6945	7205
ZM450	4500	3700 *4000	4200 *4500	4500 *5000	3055	1475	6° / 6°	6770	6970	7230
ZM500	5000	3200 *3400	3600 *4000	4000 *4200	3305	1725	6° / 6°	6805	7005	7265
ZM550	5500	2900 *3200	3200 *3600	3600 *3800	3555	1975	3° / 6°	6830	7030	7290
ZM600	6000	2600 *2900	3000 *3200	3300 *3600	3805	2225	3° / 6°	6855	7055	7315

Note: (1)*stands for the rated capacity when the front tyre is double-tyre.(2) free lifting height without lift-bracket +325mm.

WIDE VIEW FULL FREE 3-STAGE MAST										
Mast model	Max. lifting height	Load capacity (load center 500mm)(kg)			Mast height, lowered(mm)	Free lift (with backrest)(mm)	Mast tilting angle (α/β)	Service weight (kg)		
		CPCD40	CPCD45	CPCD50				CPCD40	CPCD45	CPCD50
ZSM392	3920	3840 *4000	4350 *4500	4800 *5000	2250	650	6° / 6°	6880	7080	7340
ZSM435	4350	3500 *3800	4100 *4300	4400 *4800	2395	795	6° / 6°	6900	7100	7360
ZSM450	4500	3350 *3500	4000 *4200	4300 *4600	2445	845	6° / 6°	6920	7120	7380
ZSM470	4700	3250 *3400	3800 *4000	4050 *4200	2515	955	6° / 6°	6940	7140	7400
ZSM480	4800	3150 *3300	3700 *3900	3950 *4100	2545	990	6° / 6°	6950	7150	7410
ZSM500	5000	3050 *3200	3400 *3700	3800 *4000	2645	1040	6° / 6°	6970	7170	7430
ZSM540	5400	2750 *3000	3000 *3400	3500 *3600	2760	1165	6° / 6°	7010	7210	7470
ZSM600	6000	2400 *2500	2800 *3000	3150 *3400	3010	1405	3° / 6°	7090	7290	7550

Note: (1)*stands for the rated capacity when the front tyre is double-tyre.(2) free lifting height without lift-bracket +325mm.